

**Introduction**

The 10 Gigabit Ethernet MAC Core is designed to comply with the IEEE802.3ae specification and meets the requirements for both WAN / MAN and LAN connectivity. The Version 2 of the Core can be used in either NIC (Network Interface Card) or Ethernet Switching applications. A set of configuration pins is available to dynamically set the Core to terminate and form MAC frames (NIC application) or to pass MAC frames without modification to the User application or to the Ethernet Line (Switching application). When use in NIC or Switching application, the Core provides support for IEEE managed objects, IETF MIB-II and RMON for management applications (e.g. SNMP).

The 10 Gigabit Ethernet MAC Core, on the Application side, a direct Interface that can be connected to a custom user application synchronous to the Ethernet Transmit and Receive clocks.

On the Ethernet Line side, the Core can be configured to implement either a XGMII (10 Gigabit Medium Independent Interface) or a XAUI (10 Gigabit Attachment Unit Interface) when the design is targeted to Faraday NC Express Platform Solution.

MorethanIP also provides the 10GBase-R and 10GBase-X PCS Cores that can be used, in conjunction with the 10 Gigabit Ethernet MAC, to implements XAUI or XF1 interfaces.

The core is delivered in generic synthesizable Verilog HDL code or

The Core is UNH certified and is interoperable with major PHY vendor and systems.

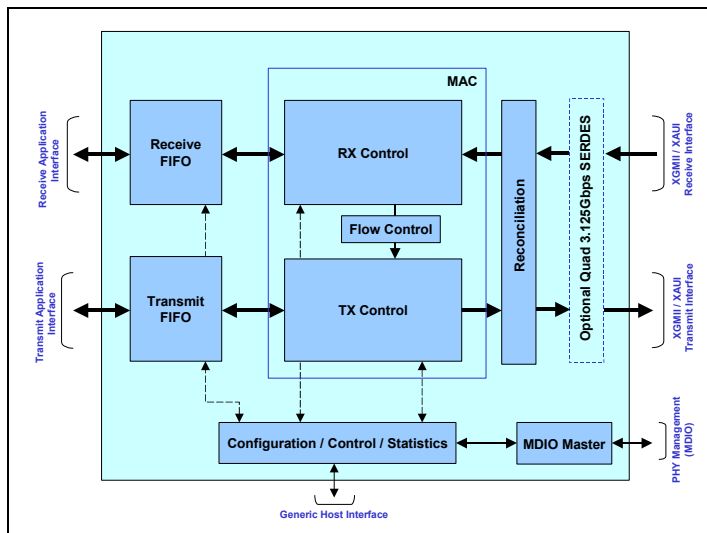

**10 Gigabit Ethernet MAC Core Block Diagram**

**10 Gigabit Ethernet MAC Core Features Overview**

- Full MAC layer and Reconciliation sub-layer implementation compliant with IEEE802.3ae specification
- Passed UNH MAC, Flow-Control, Reconciliation and Inter-Operability tests
- Can be dynamically configured for NIC (Network Interface Card) applications or Switching / Bridging applications
- Standard preamble and SFD (Start of Frame delimiter) insertion and deletion with optional insertion of a user specific 8-Byte preamble
- Lane, data alignment, PHY error and local/remote fault signaling handled by the Core's Reconciliation sub-layer
- Optional MAC address comparison on receive and overwrite on transmit for NIC applications with programmable promiscuous mode operation
- Optional Multicast address filtering with 64-bin hash code lookup table on receive reducing processing load on higher layers
- Optional Ethernet Pause Frame (802.3 Annex 31A) termination providing fully automated flow control without any user application overhead
- Optional automatic Pause Frame generation from programmable FIFO congestion thresholds or by dedicated command pin with programmable Quanta
- Programmable frame maximum length providing support for any frame (e.g. Jumbo Frame or any tagged Frame)
- Support for VLAN tagged frames according to IEEE 802.1Q specification in both transmit and receive
- Support Stacked VLAN (Q-in-Q) and MAC-in-MAC Frames
- Dynamic inter packet gap (IPG) calculation for WAN applications
- Deficit Idle Counter (DIC) for optimized performance with minimum IPG for LAN applications
- Clock and data rate decoupling with programmable asynchronous FIFOs
- Status word available with each Frame on the User interface providing information such as frame length, VLAN Frame type indication and error information
- Preamble and SFD (Start of Frame delimiter) insertion and deletion
- Optional statistics 32-Bit or 64-Bit counters for IEEE 802.3 basic and mandatory Management Information Database (MIB) package as well as Ethernet MIB (RFC 2665) and Remote Network Monitoring (RFC 2819)

**Implementation Summary**

**Faraday NC Express Implementation Summary**

Complexity (With 512 Bytes Rx and Tx FIFOs)	
Gates	RAM bits
37K to 81K	12K

**Deliverables**

- Graphical Configuration Java Tool
- Verilog Synthesizable RTL HDL or Verilog Netlist for Faraday NC Express Implementation
- Behavioral Verilog Models, Verilog testbenches with comprehensive Verification and regression test suite
- Synthesis Scripts for Synopsys Design Compiler
- Timing Constraints for Synopsys PrimeTime static time analysis tool
- Direct technical support from MorethanIP Development team

**Development Boards**

- Standard Stratix II GX FPGA Prototyping / Development Boards
- Comprehensive 10 Gigabit Ethernet PHY Selection

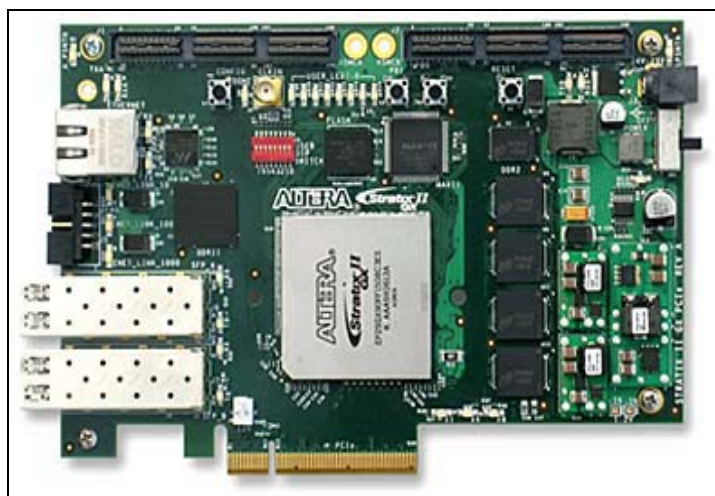

**Prototyping / Development Board**

**Ordering Code**

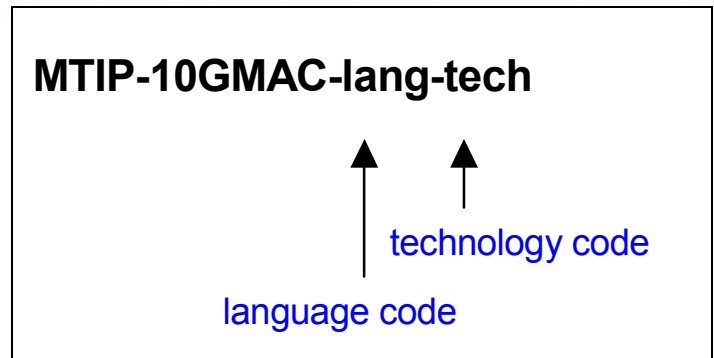

Language Code	Delivery Language
VLOG	Synthesizable Configurable RTL Verilog Source Code.
BIN	Pre-Configured Netlist for Faraday NC Express Platform Solutions.

Technology Code	Target Technology
NCEXP	Configurable Synthesizable RTL code or Pre-Configured Netlist optimized for NC Express.

**Contact**

**MorethanIP**

E-Mail : [info@morethanip.com](mailto:info@morethanip.com)  
 Internet : [www.morethanip.com](http://www.morethanip.com)

Muenchner Strasse 199  
 D-85757 Karlsfeld  
 Germany

Tel : +49 (0) 8131 333939 0  
 FAX : +49 (0) 8131 333939 1